

# FUSION

FUSIONSOLAR.CO.ZA

5kW / 8kW

## Fusion Hybrid Inverters

User Manual

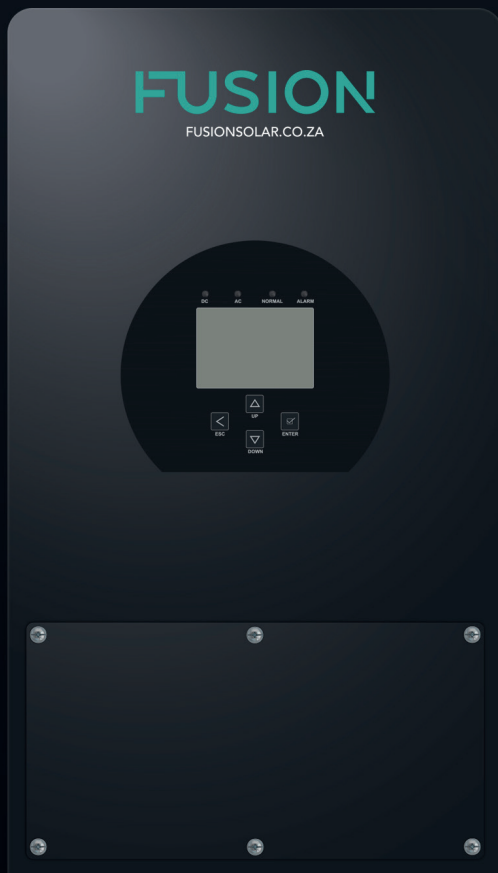

# Contents

<b>1. Safety Introductions</b>	<b>01</b>
<b>2. Product instructions</b>	<b>01-04</b>
2.1 Product Overview	
2.2 Product Features	
2.3 Basic System Architecture	
<b>3. Installation</b>	<b>04-15</b>
3.1 Parts list	
3.2 Mounting instructions	
3.3 Battery connection	
3.5 PV Connection	
3.4 AC Input/Output Connection	
3.6 CT Connection	
3.7 Earth Connection(mandatory)	
3.8 WIFI Connection	
3.9 Wiring System for Inverter	
3.10 Single phase parallel connection diagram	
3.11 Split phase parallel connection diagram	
3.12 Three phase Parallel Inverter	
<b>4. Operation</b>	<b>16</b>
4.1 Power ON/OFF	
4.2 Operation and Display Panel	
<b>5. LCD Display Icons</b>	<b>17-30</b>
5.1 Main Screen	
5.2 Solar Power Curve	
5.6 Battery Setup Menu	
5.4 System Setup Menu	
5.5 Basic Setup Menu	
5.3 Curve Page-Solar & Load & Grid	
5.7 System Work Mode Setup Menu	
5.8 Grid Setup Menu	
5.9 Generator Port Use Setup Menu	
5.10 Advanced Function Setup Menu	
5.11 Device Info Setup Menu	
<b>6. Mode</b>	<b>30-32</b>
<b>7. Fault information and processing</b>	<b>32-34</b>
<b>8. Limitation of Liability</b>	<b>35</b>
<b>9. Datasheet</b>	<b>35-36</b>

# 1. Safety Instructions

- This chapter contains important safety and operating instructions. Read and keep this manual for future reference.
- Before using the inverter, please read the instructions and warning signs of the battery and corresponding sections in the instruction manual.
- Do not disassemble the inverter. If you need maintenance or repair, take it to a professional service center.
- Improper reassembly may result in electric shock or fire.
- To reduce risk of electric shock, disconnect all wires before attempting any maintenance or cleaning. Turning off the unit will not reduce this risk.
- Caution: Only qualified personnel can install this device with battery.
- Never charge a frozen battery.
- For optimum operation of this inverter, please follow required specification to select appropriate cable size. It is very important to correctly operate this inverter.
- Be very cautious when working with metal tools on or around batteries. Dropping a tool may cause a spark or short circuit in batteries or other electrical parts, even cause an explosion.
- Please strictly follow installation procedure when you want to disconnect AC or DC terminals. Please refer to "Installation" section of this manual for the details.
- Grounding instructions - this inverter should be connected to a permanent grounded wiring system. Be sure to comply with local requirements and regulation to install this inverter.
- Never cause AC output and DC input short circuited. Do not connect to the mains when DC input short circuits.

# 2. Product Introduction

This is a multifunctional inverter, combining functions of inverter, solar charger and battery charger to offer uninterruptible power support with portable size. Its comprehensive LCD display offers user configurable and easy accessible button operation such as battery charging, AC/solar charging, and acceptable input voltage based on different applications.

## 2.1 Product Overview

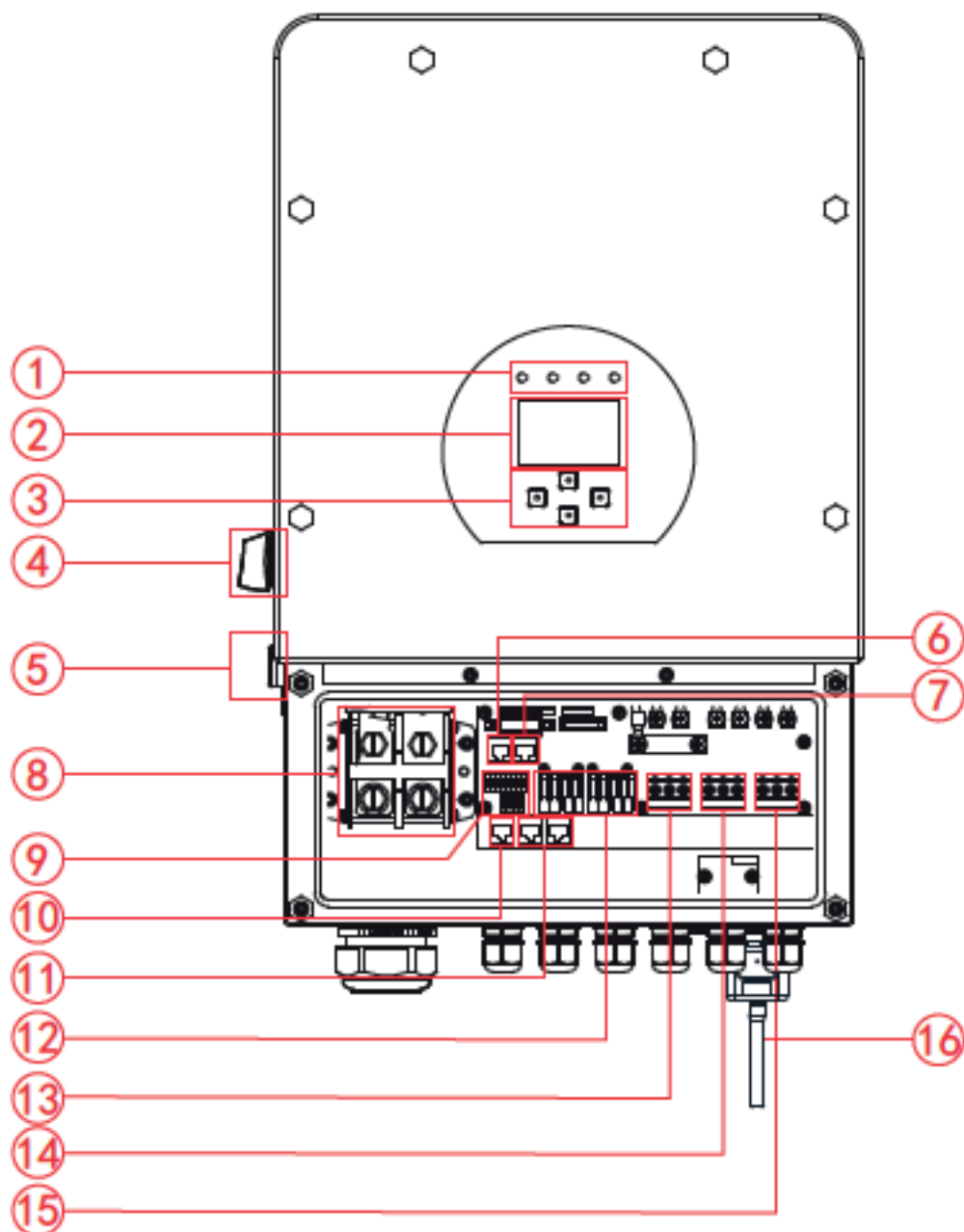

1: Inverter Indicators

2: LCD display

3: Function Buttons

4: DC Switch

5: Power on/off button

6: RS 485 Port

7: CAN Port

8: Battery input connectors

9: Function Port

10: Parallel Box(master)

11: Parallel port

12: PV input with two MPPT

13: Grid

14: Generator input

15: Load

16: WiFi Interface

## 2.2 Product Features

- 220V Single phase, 120V/240V Split phase Pure sine wave inverter.
- Self-consumption and feed-in to the grid.
- Auto restart while AC is recovering.
- Programmable supply priority for battery or grid.
- Programmable multiple operation modes: On grid, off grid and UPS.
- Configurable battery charging current/voltage based on applications by LCD setting.
- Configurable AC/Solar/Generator Charger priority by LCD setting.
- Compatible with mains voltage or generator power.
- Overload/over temperature/short circuit protection.
- Smart battery charger design for optimized battery performance
- With limit function, prevent excess power overflow to the grid.
- Supporting WIFI monitoring and build-in 2 strings of MPP trackers
- Smart settable three stages MPPT charging for optimized battery performance.
- Time of use function.
- Smart Load Function.

## 2.3 Basic System Architecture

The following illustration shows basic application of this inverter.

It also includes following devices to have a Complete running system.

- Generator or Utility
- PV modules

Consult with your system integrator for other possible system architectures depending on your requirements.

This inverter can power all kinds of appliances in home or office environment, including motor type appliances such as refrigerator and air conditioner.

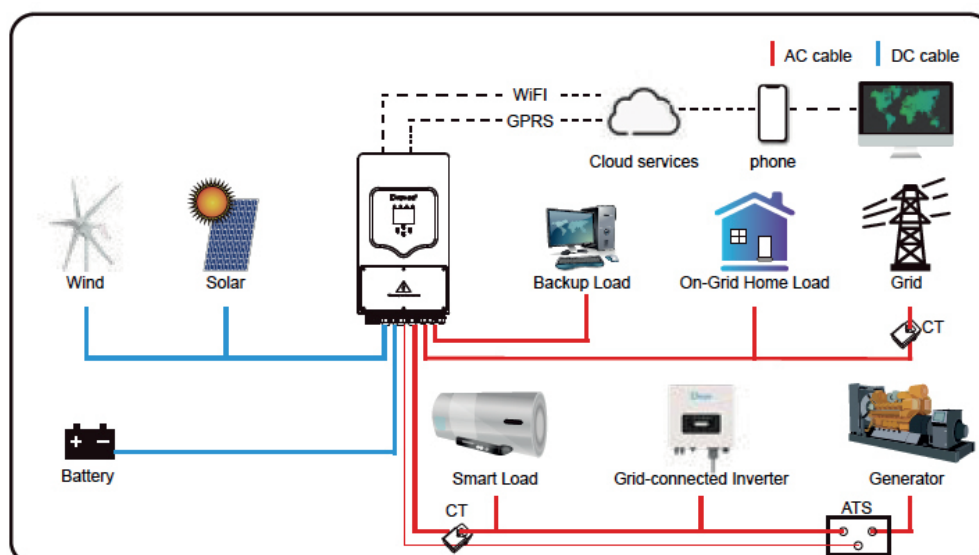

# 3. Instillation

## 3.1 Parts List

Check the equipment before installation. Please make sure nothing is damaged in the package. You should have received the items in the following package:

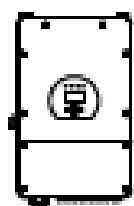

1



2



3



4



5



6



7

Chart 3-1 Parts List

No	Decription	Qty
1	Fusion 5kW Hybrid Inverter Fusion 8kW Hybrid Inverter	1
2	Stainless steel expansion bolts M8*80	4
3	User manual	1
4	WiFi plug	1
5	Current transformer (Optional)	1
6	Battery sensor	1
7	L-type Hexagon wrench	1

## 3.2 Mounting Instructions

### Installation Precaution

This Hybrid inverter is designed for outdoor use(IP65),Please make sure the installation site meets below conditions:

- Not in direct sunlight
- Not in areas where highly flammable materials are stored.
- Not in potential explosive areas.
- Not in the cool air directly.
- Not near the television Antenna or antenna cable.
- Not higher than altitude of about 2000 meters above sea level.
- Not in environment of precipitation or humidity(>95%)

Please AVOID direct sunlight, rain exposure, snow laying up during installation and operation. Before connecting all wires,please take off the metal cover by removing screws as shown below:

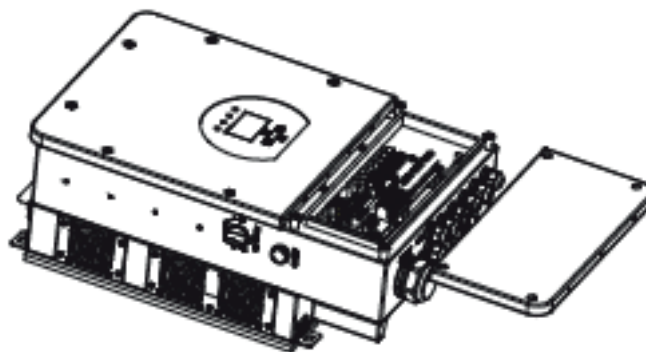

### Considering the following points before selecting where to install:

- Please select a vertical wall with load-bearing capacity for installation, suitable for installation on concrete or other non-flammable surfaces,installation is shown below.
- Install this inverter at eye level in order to allow the LCD display to be read at all times.
- The ambient temperature should be between -25~60℃ to ensure optimal operation.
- Be sure to keep other objects and surfaces as shown in the diagram to guarantee sufficient heat dissipation and have enough space for removing wires.

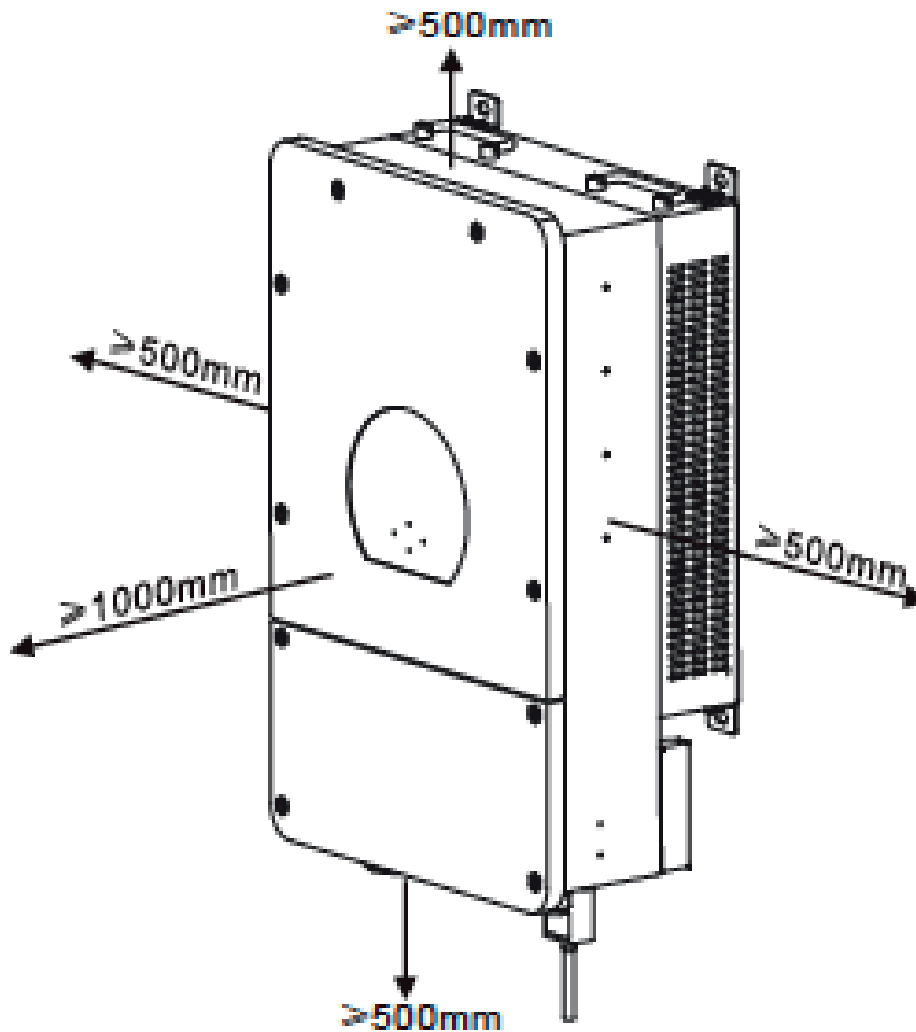

For proper air circulation to dissipate heat, allow a clearance of approx. 50cm to the side and approx.50cm above and below the unit.And 100cm to the front.

### **Mounting the inverter**

Remember that this inverter is heavy!Please be careful when lifting out from the package. Choose the recommend drill head(as shown in below pic) to drill 4 holes on the wall, 52-60mm deep.

1. Use a proper hammer to fit the expansion bolt into the holes.
2. Carry the inverter and holding it,make sure the hanger aim at the expansion bolt,fix the inverter on the wall.
3. Fasten the screw head of the expansion bolt to finish the mounting.



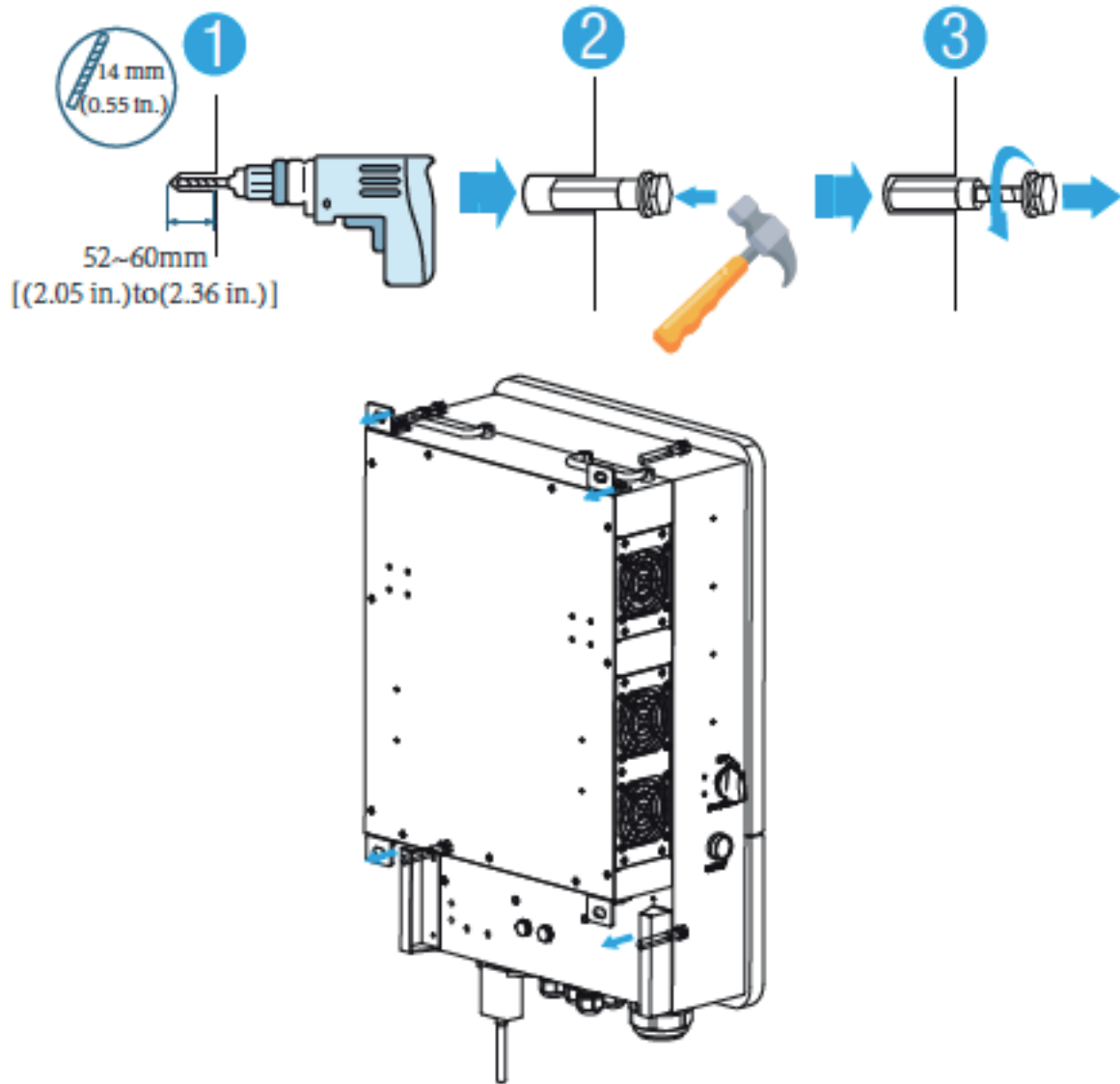

### 3.3 Battery Connection

For safe operation and compliance, a separate DC over-current protector or disconnect device is required between the battery and the inverter. In some applications, switching devices may not be required but over-current protectors are still required. Refer to the typical amperage in the table below for the required fuse or circuit breaker size.

Please AVOID direct sunlight, rain exposure, snow laying up during installation and operation. Before connecting all wires, please take off the metal cover by removing screws as shown below:

Chart 3-2 Cable Size

Model	Wire Size	Cable(mm <sup>2</sup> )	Torque value (max)
5/8kW	2AWG	35	24.5Nm



All wiring must be performed by a professional person.



Connecting the battery with a suitable cable is important for safe and efficient operation of the system. To reduce the risk of injury, refer to Chart 3-2 for recommended cables.

Please follow below steps to implement battery connection:

1. Please choose a suitable battery cable with correct connector which can well fit into the battery terminals. 2. Use a suitable screwdriver to unscrew the bolts and fit the battery connectors in, then fasten the bolt by the screwdriver, make sure the bolts are tightened with torque of 24.5 N.M.

2. Nm in clockwise direction, make sure polarity at both the battery and inverter is correctly connected.

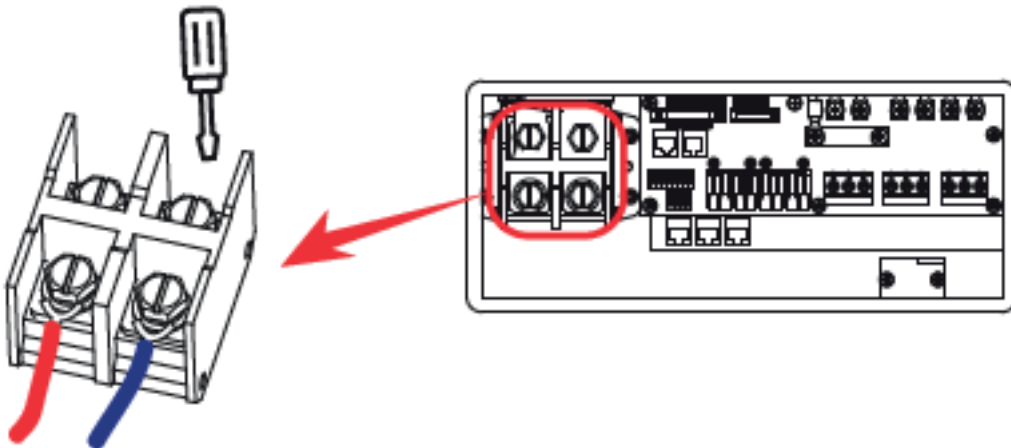

3. In case of children touch or insects go into the inverter, please make sure the inverter connector is fastened to waterproof position by twisting it clockwise.



Installation must be performed with care.



Before making the final DC connection or closing DC breaker/disconnect, be sure positive(+) must be connected to positive(+) and negative(-) must be connected to negative(-). Reverse polarity connection on battery will damage the inverter.

### 3.3.2 Battery Temperature Connection

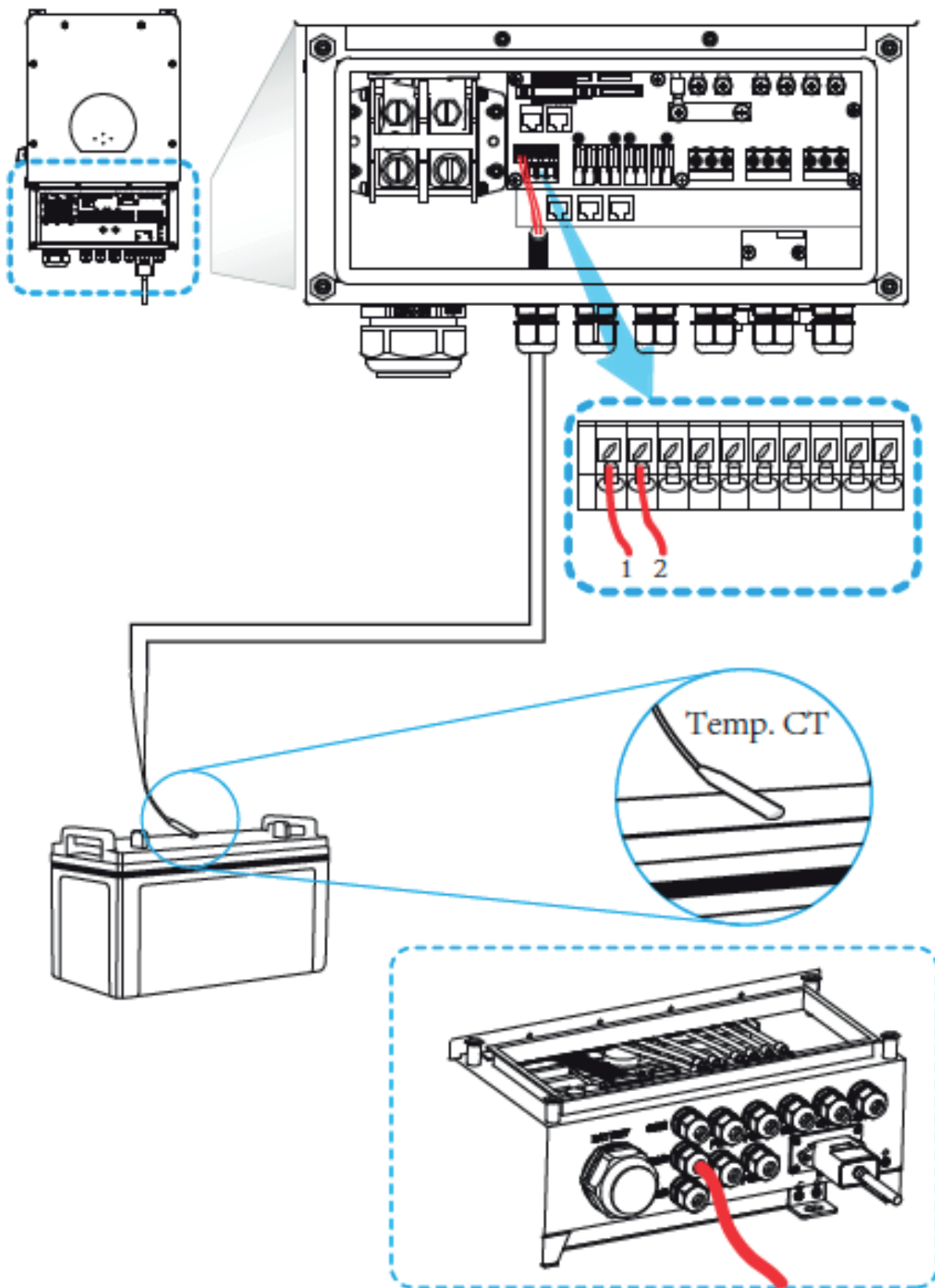

## 3.4 AC Input/Output Connection

- Before connecting to AC input power source, please install a separate AC breaker between inverter and AC input power source. This will ensure the inverter can be securely disconnected during maintenance and fully protected from over current of AC input. The recommended of AC breaker is 50A for 5kw and 80A for 8KW.
- There are three terminal blocks with "Grid""Load"and "GEN"markings. Please do not misconnect input and output connectors.



All wiring must be performed by a qualified personnel. It is very important for system safety and efficient operation to use appropriate cable for AC input connection. To reduce risk of injury, please use the proper recommended cable as below.

**Chart 3-3 Recommended Size for AC Wires**

Model	Wire Size	Cable(mm <sup>2</sup> )	Torque value
5KW	8AWG	8	1.2Nm
8KW	6AWG	13	1.2Nm

**Please follow below steps to implement AC input/output connection:**

1. Before making AC input/output connection, be sure to open DC protector or disconnect first.
2. Remove insulation sleeve 10mm length, unscrew the bolts, insert the AC input wires according to polarities indicated on the terminal block and tighten the terminal screws. Make sure the connection is complete.

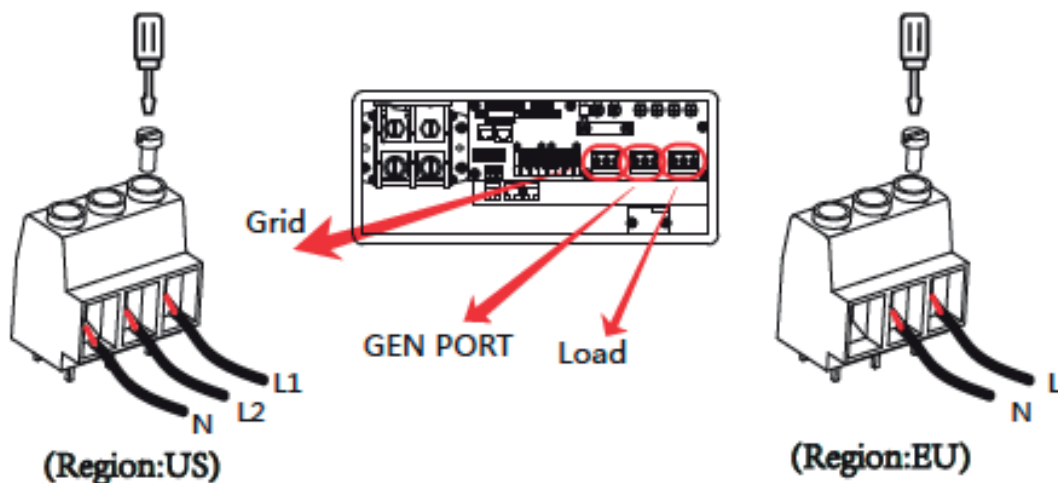



Be sure that AC power source is disconnected before attempting to wire it to the unit.

3. Then, insert AC output wires according to polarities indicated on the terminal block and tighten terminal. Be sure to connect corresponding N wires and PE wires to related terminals as well.

4. Make sure the wires are securely connected.

5. Appliances such as air conditioner are required at least 2-3 minutes to restart because it is required to have enough time to balance refrigerant gas inside of circuit. If a power shortage occurs and recovers in short time, it will cause damage to your connected appliances. To prevent this kind of damage, please check manufacturer of air conditioner if it is equipped with time-delay function before installation. Otherwise, this inverter will trigger overload fault and cut off output to protect your appliance but sometimes it still causes internal damage to the air conditioner.

## 3.5 PV Connection

Before connecting to PV modules, please install a separately DC circuit breaker between inverter and PV modules. It is very important for system safety and efficient operation to use appropriate cable for PV module connection. To reduce risk of injury, please use the proper recommended cable size as below.

**Chart 3-4 Cable size**

Model	Wire Size	Cable(mm <sup>2</sup> )	Torque value
5/8KW	12AWG	4	1.2Nm



To avoid any malfunction, do not connect any PV modules with possible current leakage to the inverter. For example, grounded PV modules will cause current leakage to the inverter. When using PV modules, please be sure NO grounding.



It is requested to use PV junction box with surge protection. Otherwise, it will cause damage on inverter when lightning occurs on PV modules.

## 3.5.1 PV Module Selection:

When selecting proper PV modules, please be sure to consider below parameters:

1. Open circuit Voltage (Voc) of PV modules not exceeds max. PV array open circuit voltage of inverter.
2. Open circuit Voltage (Voc) of PV modules should be higher than min. start voltage.

Chart 3-5

Inverter Model	5KW	8KW
PV Input Voltage (V)	370V(100V~500V)	
PV Array MPPT Voltage Range	125Vdc-425Vdc	
No. of MPP Trackers	2	
No. of Strings per MPP Tracker	1+1	2+2

## 3.5.2 PV Module Wire Connection:

Please follow below steps to implement PV module connection:

1. Remove insulation sleeve 10 mm for positive and negative conductors.
2. Suggest to put bootlace ferrules on the end of positive and negative wires with a proper crimping tool.
3. Check correct polarity of wire connection from PV modules and PV input connectors. Then, connect positive pole (+) of connection wire to positive pole (+) of PV input connector. Connect negative pole (-) of connection wire to negative pole (-) of PV input connector. Close the switch and make sure the wires are tightly fixed.

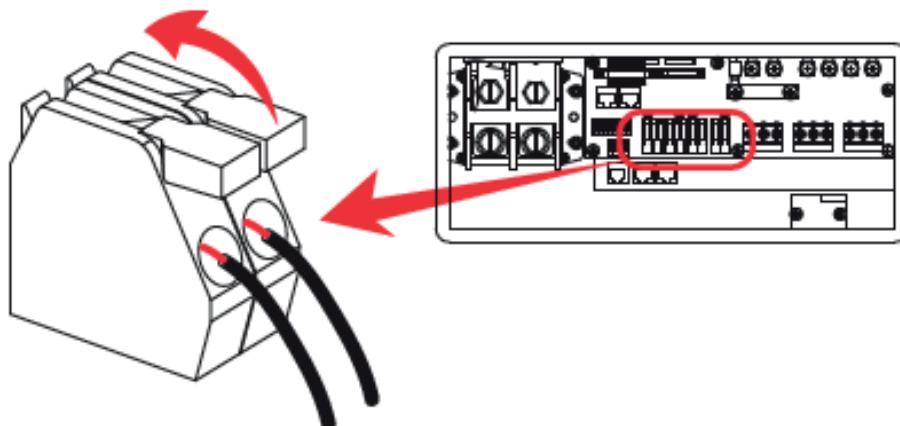

### 3.5.1 PV Module Selection:

(Region: EU)

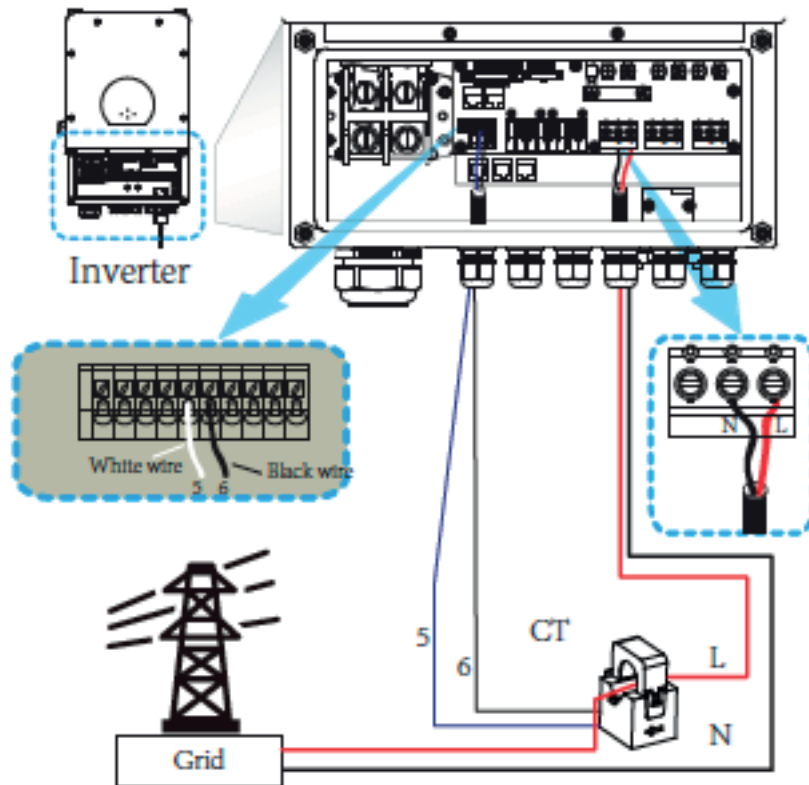

(Region: US)

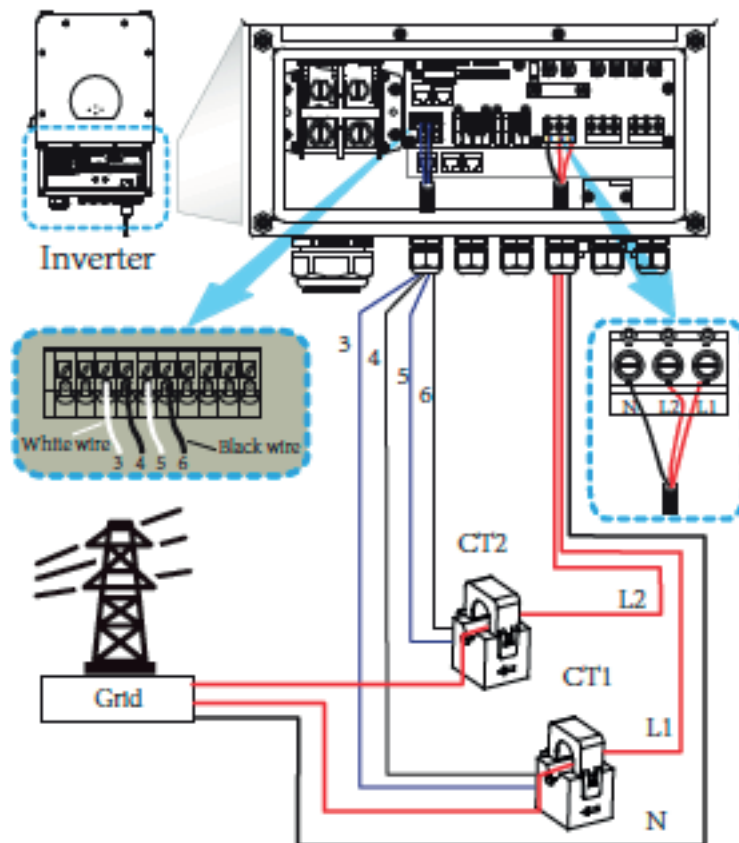

## Note:

When the inverter is in the off-grid state, the N line needs to be connected to the earth.

### 3.7 Earth Connection (Mandatory)

Ground cable shall be connected to ground plate on grid side this prevents electric shock. if the original protective conductor fails.

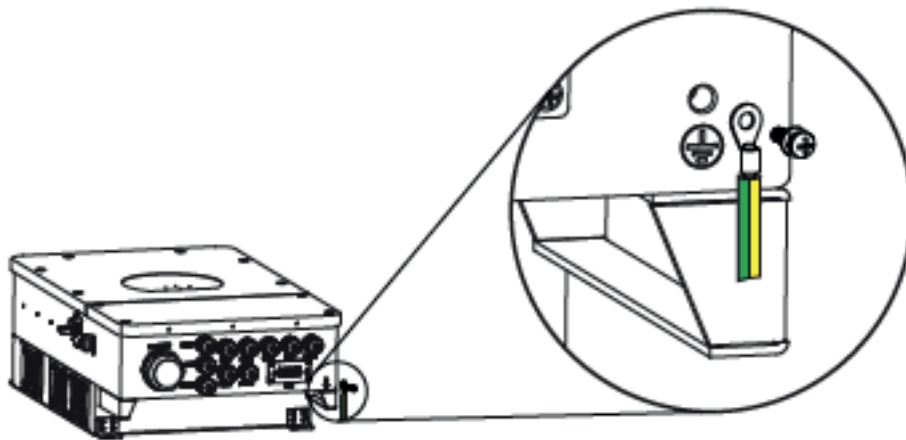

### 3.8 WIFI Connection

For the configuration of Wi-Fi Plug, please refer to illustrations of the Wi-Fi Plug.



# 3.9 Wiring System for Inverter

(Region: EU)

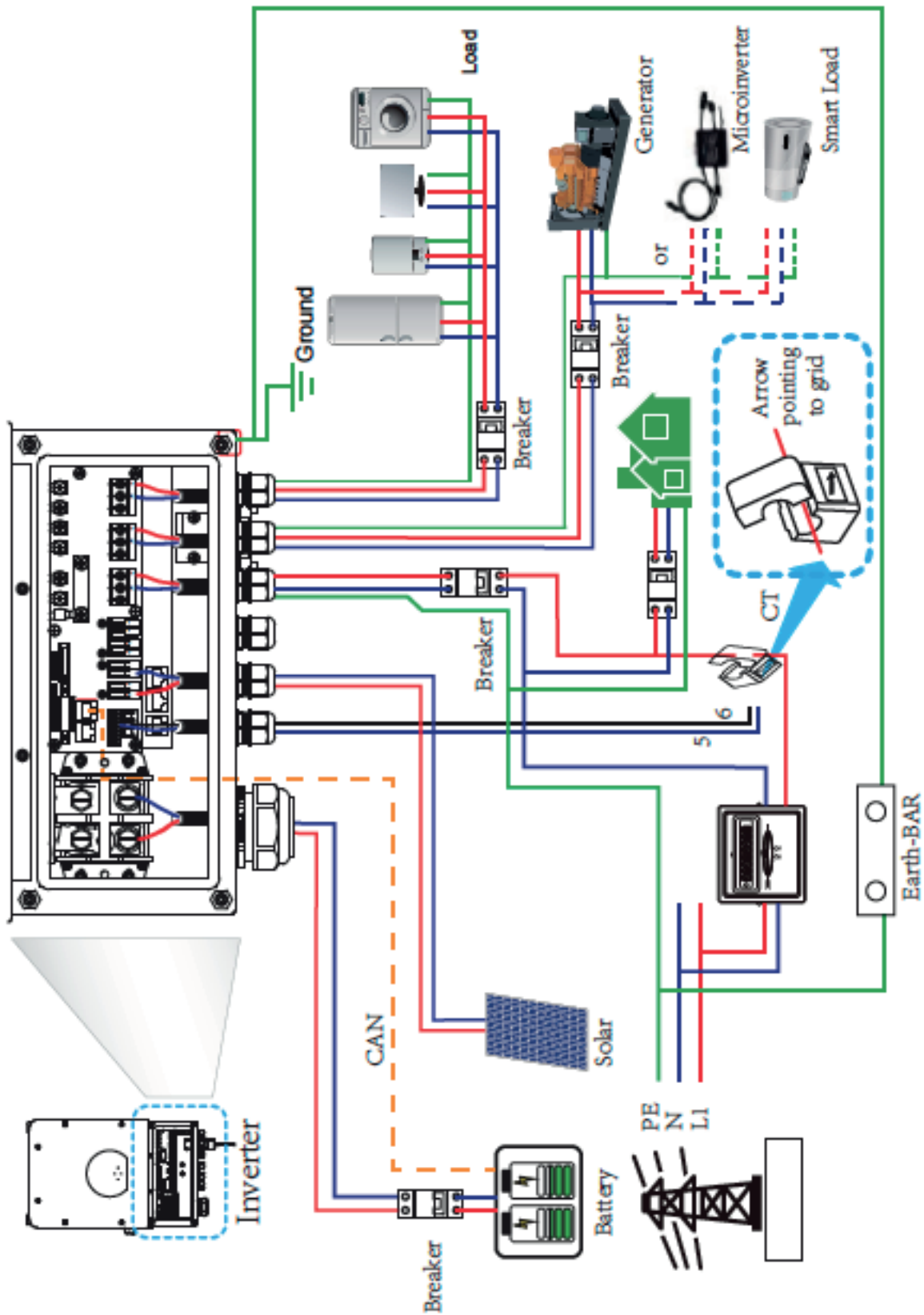

(Region: US)

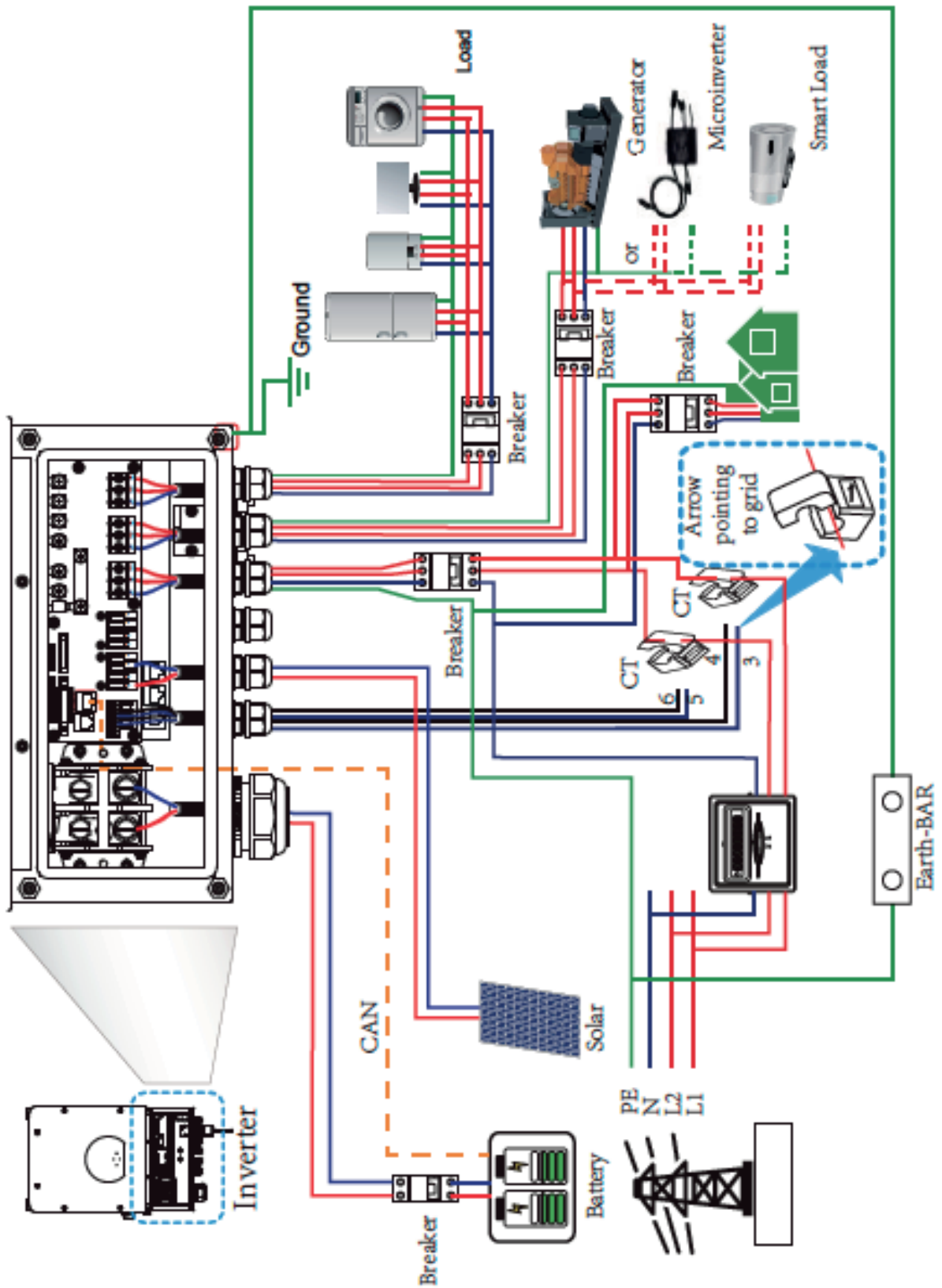

# 3.10 Single Phase Parallel Connection Diagram

(Region: EU)

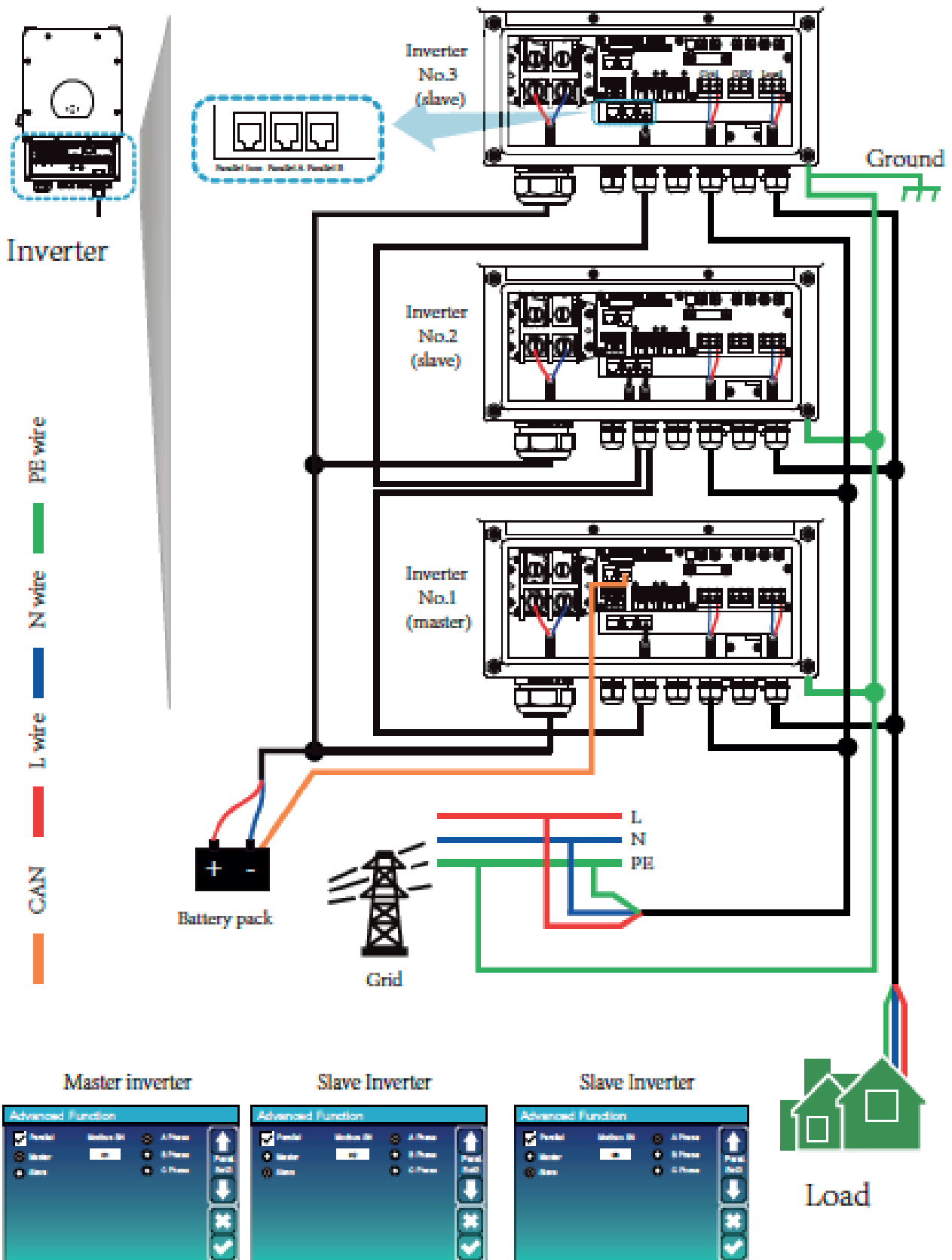

# 3.11 Split Phase Parallel Connection Diagram

(Region: US)

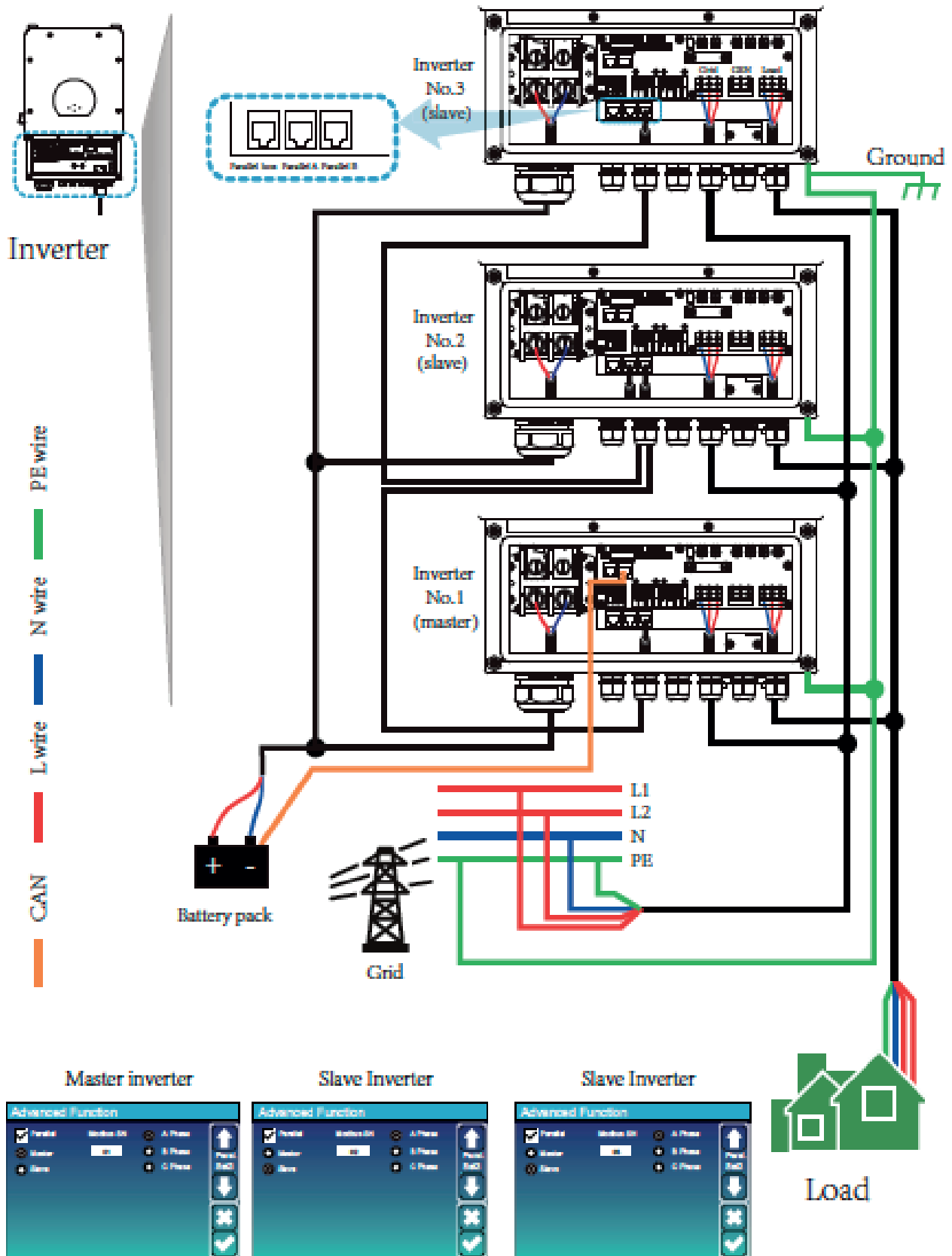

# 3.12 Three Phase Parallel Inverter

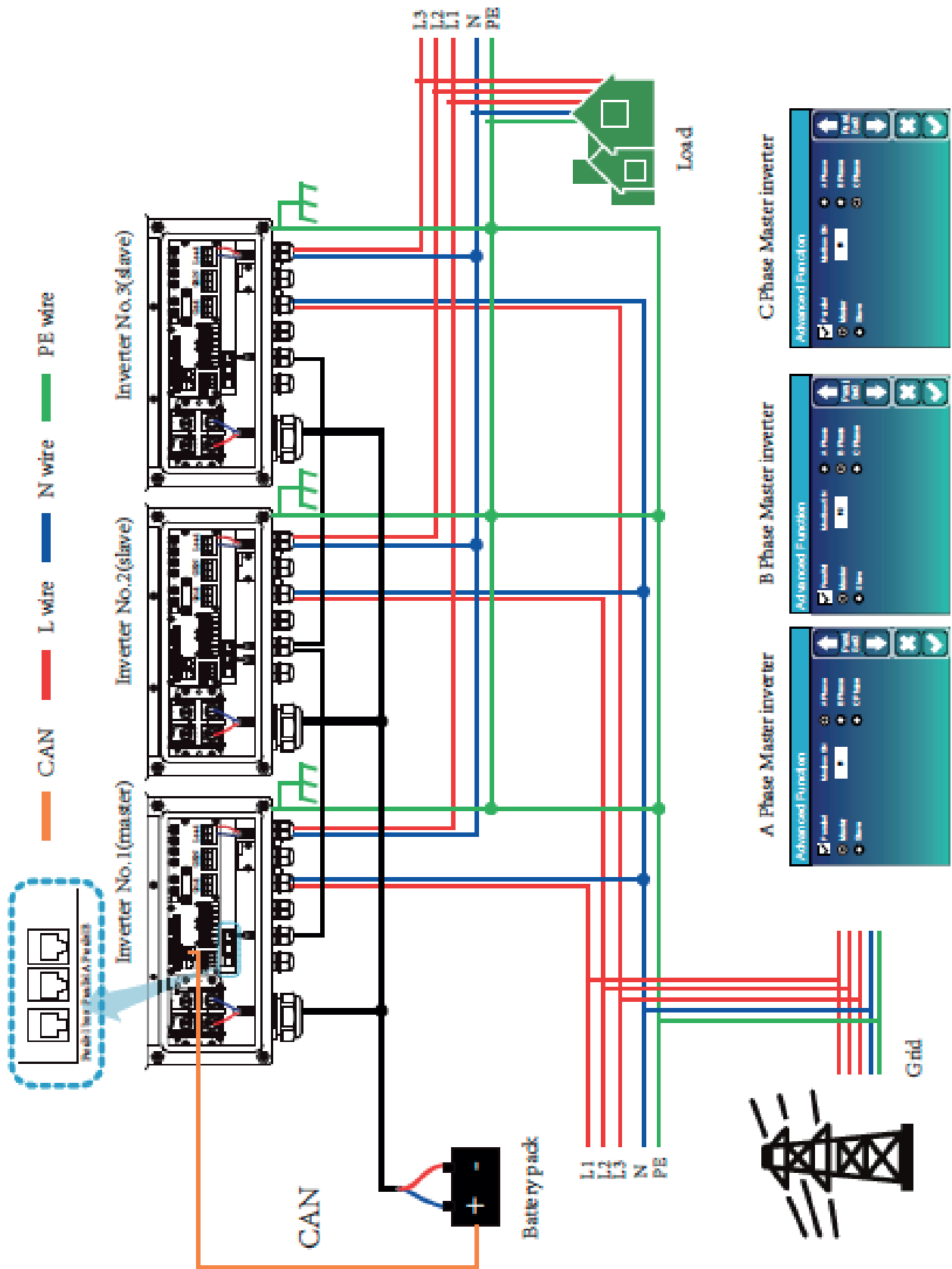

## 4. Operation

### 4.1 Power ON/OFF

Once the unit has been properly installed and the batteries are connected well, simply press On/Off button (located on the left side of the case) to turn on the unit. When system without battery connected, but connect with either PV or grid, and ON/OFF button is switched off, LCD will still light up (Display will show OFF). In this condition, when switch on ON/OFF button and select NO battery, system can still working.

### 4.2 Operation and Display Panel

The operation and display panel, shown in below chart, is on the front panel of the inverter. It includes four indicators, four function keys and a LCD display, indicating the operating status and input/output power information.

**Chart 4-1 LED indicators**

LED Indicator		Messages
DC	Green led solid light	PV Connection normal
AC	Green led solid light	Grid Connection normal
Normal	Green led solid light	Inverter operating normal
Alarm	Red led solid light	Malfunction or warning

**Chart 4-2 Function Buttons**

Function Key	Description
Esc	To exit setting mode
Up	To go to previous selection
Down	To go to next selection
Enter	To confirm the selection

## 5. LCD Display Icons

### 5.1 Main Screen

The LCD is touchscreen, below screen shows the overall information of the inverter.

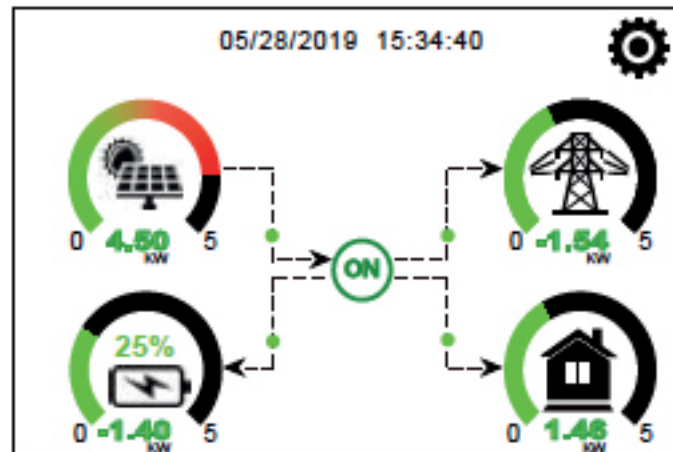

1. The icon in the center of the home screen indicates that the system is Normal operation. If it turns into "comm./F01~F64", it means the inverter has communication errors or other errors, the error message will display under this icon (F01-F64 errors, detail error info can be viewed in the System Alarms menu).

2. At the top of the screen is the time.

3. System Setup Icon, Press this set button, you can enter into the system setup screen which including Basic Setup, Battery Setup, Grid Setup, System Work Mode, Generator port use, Advanced function and Li-Batt info.

4. The main screen showing the info including Solar, Grid, Load and Battery. Its also displaying the energy flow direction by arrow. When the power is approximate to high level, the color on the panels will changing from green to red so system info showing vividly on the main screen.

- PV power and Load power always keep positive.
- Grid power negative means sell to grid, positive means get from grid.
- Battery power negative means charge, positive means discharge.

## 5.1.1 LCD operation flow chart

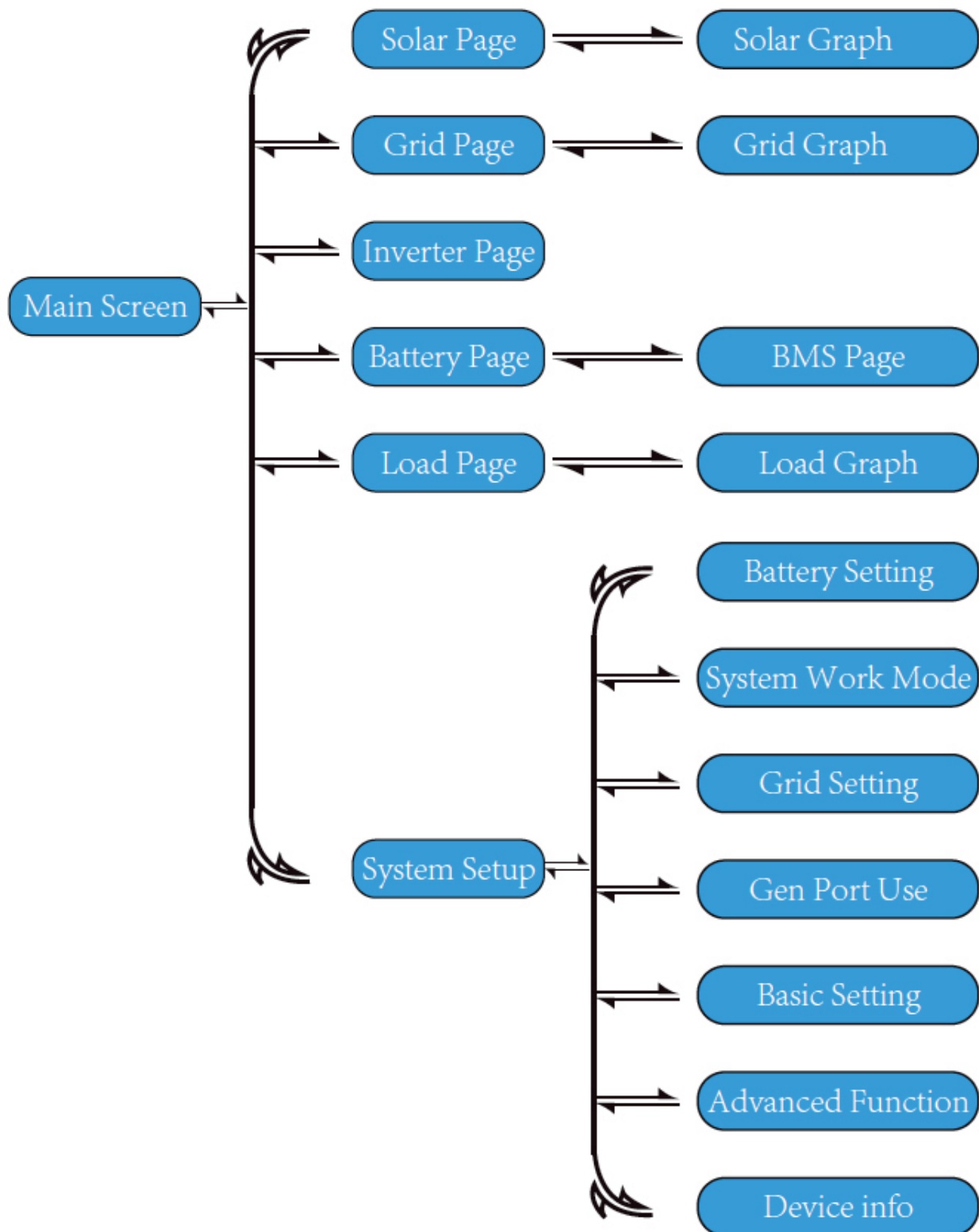



## 5.2 Solar Power Curve



This is Solar Panel detail page.

- ① Solar Panel Generation.
- ② Voltage,Current,Power for each MPPT.
- ③ Solar Panel energy for Day and Total.

Press the “Energy “button will enter into the power curve page.

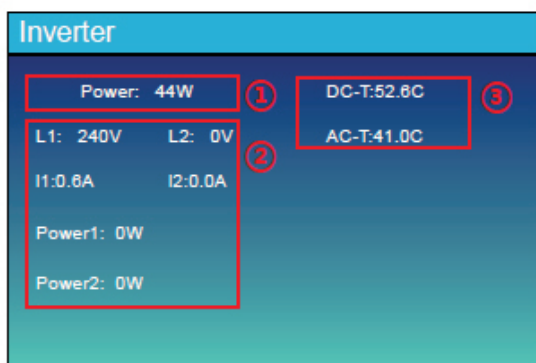

This is Inverter detail page.

- ① Inverter Generation.
- ② Voltage,Current,Power for each Phase.
- ③ DC-T:mean DC-DC temperature,  
AC-T:mean Heat-sink temperature.

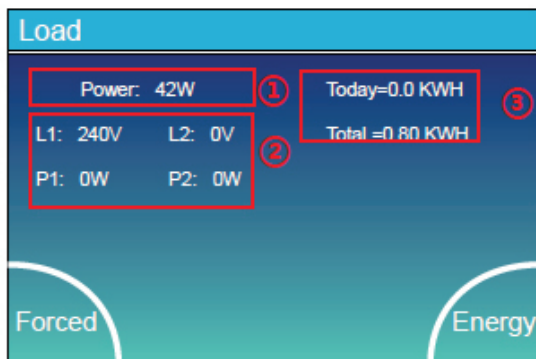

This is Back-up Load detail page.

- ① Back-up Power.
- ② Voltage,Power for each Phase.
- ③ Back-up consumption for Day and Total.

Press the “Energy “button will enter into the power curve page.

Press the “Forced “button will forced open the smart-load(While GEN PORT utilized as Smart-load output).



This is Grid detail page.

- ① Status,Power,Frequency.
- ② L1&L2:Voltage for each Phase  
CT1&CT2:External Current Sensor Power  
LD1&LD2:Internal Current Sensor Power.
- ③ BUY:Energy from Grid to Inverter,  
SELL:Energy from Inverter to Load.

Press the “Energy “button will enter into the power curve page.

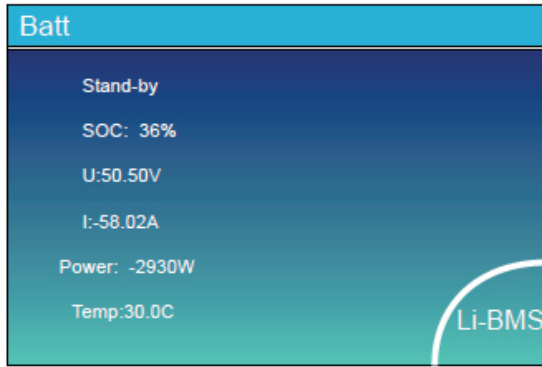

This is Battery detail page.  
if you use Lithium Battery, you can enter BMS page.

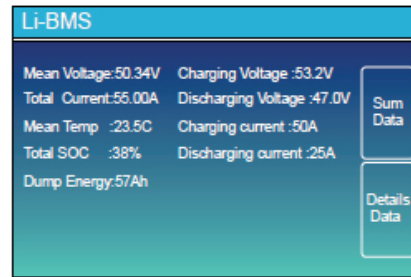

	Volt	Curr	Temp	SOC	Energy	Charge	Fault
1	50.38V	19.70A	30.8C	52.0%	29.0Ah	0.0V 0.0A	0x00
2	50.35V	19.10A	31.0C	51.0%	25.5Ah	53.2V 25.0A	0x00
3	50.35V	18.90A	30.2C	12.0%	6.0Ah	53.2V 25.0A	0x00
4	0.00V	0.00A	0.0C	0.0%	0.0Ah	0.0V 0.0A	0x00
5	0.00V	0.00A	0.0C	0.0%	0.0Ah	0.0V 0.0A	0x00
6	0.00V	0.00A	0.0C	0.0%	0.0Ah	0.0V 0.0A	0x00
7	0.00V	0.00A	0.0C	0.0%	0.0Ah	0.0V 0.0A	0x00
8	0.00V	0.00A	0.0C	0.0%	0.0Ah	0.0V 0.0A	0x00
9	0.00V	0.00A	0.0C	0.0%	0.0Ah	0.0V 0.0A	0x00
10	0.00V	0.00A	0.0C	0.0%	0.0Ah	0.0V 0.0A	0x00
11	0.00V	0.00A	0.0C	0.0%	0.0Ah	0.0V 0.0A	0x00
12	0.00V	0.00A	0.0C	0.0%	0.0Ah	0.0V 0.0A	0x00
13	0.00V	0.00A	0.0C	0.0%	0.0Ah	0.0V 0.0A	0x00
14	0.00V	0.00A	0.0C	0.0%	0.0Ah	0.0V 0.0A	0x00
15	0.00V	0.00A	0.0C	0.0%	0.0Ah	0.0V 0.0A	0x00

## 5.3 Curve Page-Solar & Load & Grid

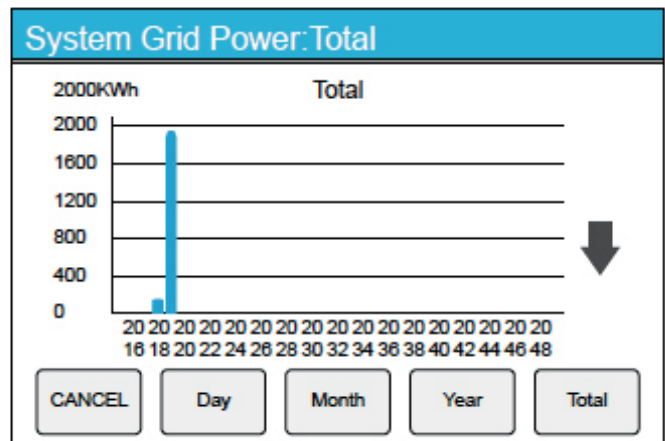
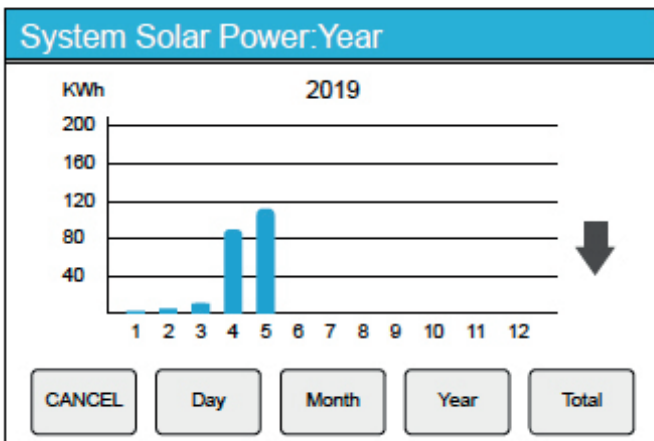
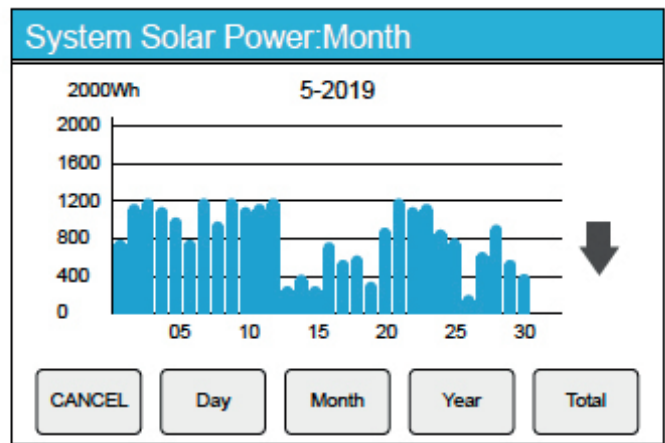
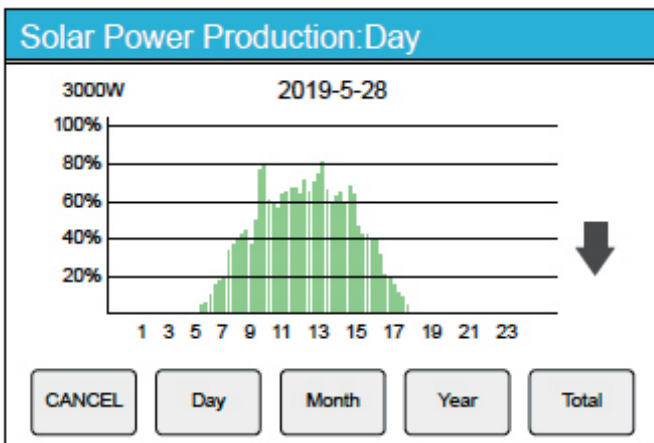

Solar power curve for daily, monthly, yearly and total can be roughly checked on the LCD. For more accuracy power generation, please check on the monitoring system. Click the up and down arrow to check power curve of different period.

## 5.4 System Setup Menu

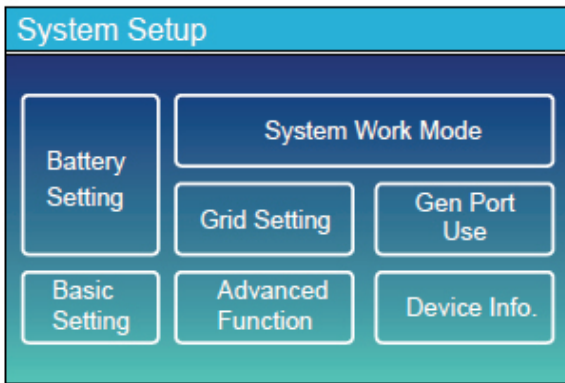

This is System Setup page.

## 5.5 Basic Setup Menu

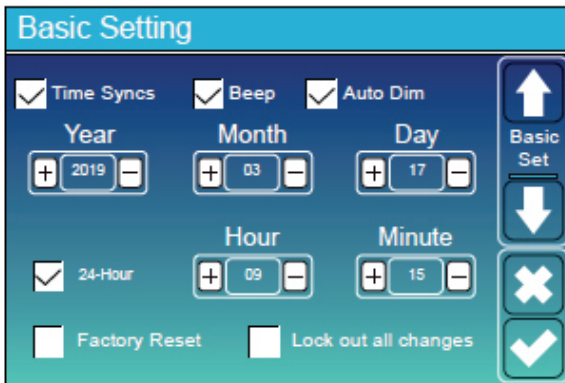

This is Basic Setup page.

## 5.6 Battery Setup Menu

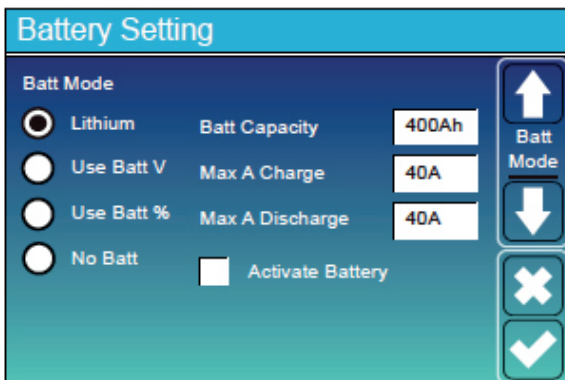

### Lithium Battery

Batt Mode----- Lithium  
 Max A charge----- 0-120A  
 Max A Discharge-----0-120A  
 Activate Battery-----Enable

### AGM Battery

Batt Mode----- Use Batt V or Use Batt V%  
 Batt Capacity----- 50-2000Ah  
 Max A charge----- 0-120A  
 Max A Discharge-----0-120A  
 Activate Battery -----Enable

No Batt --- No need to set other parameters,  
 keep the default value.

**Battery Setting**

Start	30%	30%	②
A	40A	40A	
<input type="checkbox"/> Gen Charge		<input type="checkbox"/> Grid Charge	
<input type="checkbox"/> Gen Signal		<input type="checkbox"/> Grid Signal	
Gen Max Run Time	0.0 hours	0.0 hours	③
Gen Down Time	0.5 hours		

↑ Batt Set2  
↓  
✕  
✓

This is Battery Setup page. ① ③

Start =30%---It indicates that the Generator will start when the Battery capacity is less than 30% in Off-grid mode.

A = 40A---It indicates the Current that the Generator charges the Battery after starting.

Gen Charge---It indicates the Switch that the Generator charges the Battery.

Gen Signal ---It indicates whether the Generator's ATS signal is on or off.

Gen Max RunTime ---It indicates the longest time Generator can run in one day, when time is up, the Generator will be turned off. 24H means that it does not shut down all the time.

Gen DownTime ---It indicates the delay time of the Generator to shut down after it has reached the running time.

This is Grid Charge, you need select. ②

Start =30%---No use, Just for customization.

A = 40A--- It indicates the Current that the Grid charges the Battery.

Grid Charge---It indicates that the grid charges the battery.

Grid Signal ---Disable.

**Battery Setting**

Lithium Mode	00
Shutdown	10%
Low Batt	30%
Restart	80%

↑ Batt Set3  
↓  
✕  
✓

Lithium Mode--This is BMS protocol.Please reference the document (Approved Battery) .

Shutdown 10%--It indicates the inverter will shutdown if the SOC below this value.

Low Batt 20% --It indicates the inverter will alarm if the SOC below this value.

Restart 40% --It indicates the restart level when inverter shutdown.

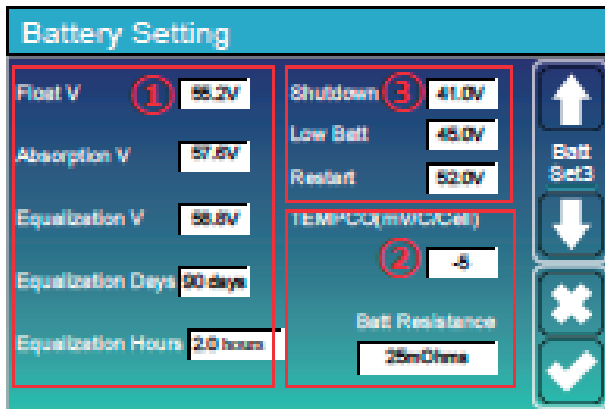

This is Battery 4 tages charge voltage. ①

This is for professional installers, you can hold default if you do not know. ②

Shutdown 10%--the inverter will shutdown if the SOC is below this.  
 Low Batt 20% --the inverter will alarm if the SOC is below this. ③  
 Restart 40% --Restart level when inverter shutdown.

## 5.7 System Work Mode Setup Menu

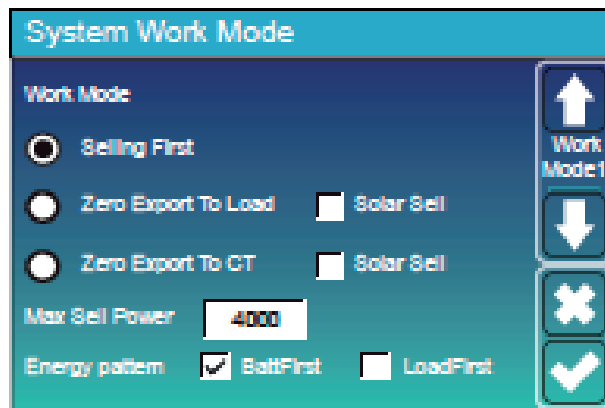

**Work Mode**  
**Selling First** : It means that the excess energy has priority in grid connection.  
**Zero Export To Load**: It means output power according to it consumed by the load.  
**Zero Export To CT** : It means output power according to the CT position.  
**Solar Sell** : It means that the excess solar energy can be integrated into the grid.  
**Max Sell Power 0-8000W**  
**Energy Pattern**  
**BattFirst**--- It means solar power will charge battery first, when battery is full then feed-out power to the Load or Grid.  
**LoadFirst**-- The solar energy will be used to supply the local load first, then to charge the battery. The redundant power will export to the public grid.

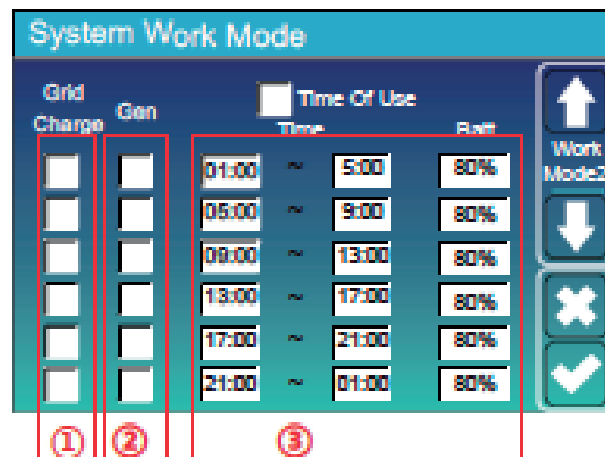

**Time of use**  
 ① Switch for Grid charging the battery.  
 ② Switch for Gen charging the battery.  
 ③ There are six time period can be set, each period must from small to large.

## 5.8 Grid Setup Menu

**Grid Setting**

Grid Mode

- General Standard
- UL1741 & IEEE1547
- CPUC RULE21
- SRD-UL-1741

Grid Type

- 220V Single Phase
- 120/240V Split Phase
- 120/208V 3 Phase
- 120V Single Phase

Grid Set1

Please select the correct Grid Mode in your local area. If you are not sure, please choose General Standard.

Please select the correct Grid Type in your local area, otherwise the machine will not work or be damaged.

**Grid Setting**

Grid Frequency

- 50Hz
- 60Hz

Reconnection Time:  PF:

Grid HZ High:  Grid Vol High:

Grid HZ Low:  Grid Vol Low:

Grid Set2

UL1741&IEEE1547, CPUC RULE21, SRD-UL-1741

No need to set the function of this interface.

General Standard

Please select the correct Grid Frequency in your local area. You can hold this in default value.

**Grid Setting**

Q(V)     FW     VW

V1:0.0V    Q1:0.00    Fstart:0.00Hz    Vstart:0.0V

V2:0.0V    Q2:0.00    Fstop:0.00Hz    Vstop:0.0V

V3:0.0V    Q3:0.00    Normal Ramp rate:

V4:0.0V    Q4:0.00    Soft Start Ramp rate:

Grid Set3

For California only.

**Grid Setting**

LHVRT     LHFRT

HV2:0.0V    0.16S

HV1:0.0V    0.16S    HF2:0.00Hz    0.16S

LV1:0.0V    0.16S    HF1:0.00Hz    0.16S

LV2:0.0V    0.16S    LF1:0.00Hz    0.16S

LV3:0.0V    0.16S    LF2:0.00Hz    0.16S

Grid Set4

For California only.

## 5.9 Generator Port Use Setup Menu

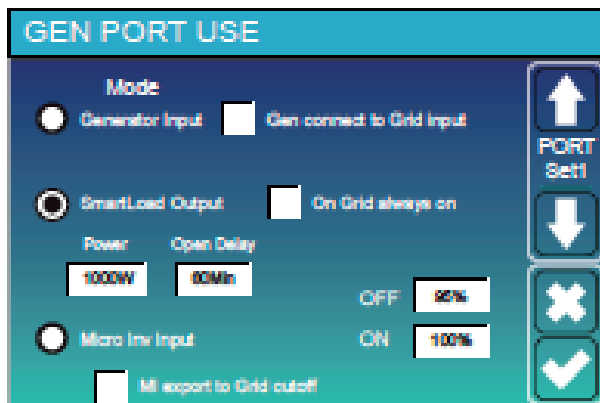

Generator Input:use Generator

SmartLoad Output: if the SOC is up than "ON" and solar power is high than 1000W. the inverter will open smartload.

On Grid always on:mean when have Grid,the smartload will always on

Micro Inv Input:Inverter will open

Microinverter.if the SOC is below the "ON" and close if the SOC is up than the "OFF"

## 5.10 Advanced Function Setup Menu

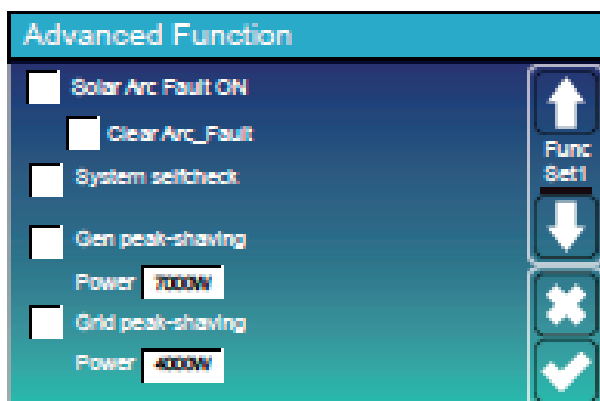

Solar Arc Fault ON---This is only for US.

System selfcheck ---Disable. this is only for factory.

Gen Peak-shaving---Enable When the power of the generator exceeds the rated value of it, the inverter will provide the redundant part to ensure that the generator will not overload.

Grid Peak-shaving---Enable When the power of the grid exceeds the set value, the inverter will provide the redundant part to ensure that the grid power does not exceed the set value.



This is for Wind Turbine

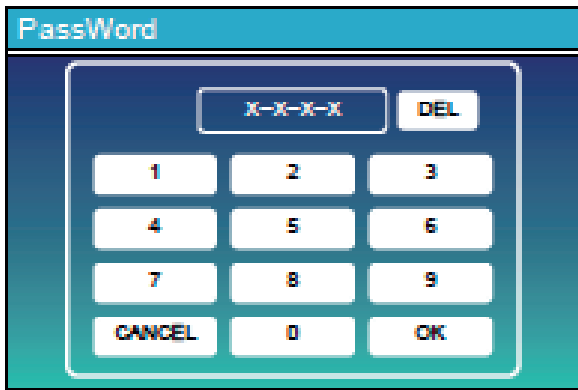

Factory Reset: 9999  
 Lock out all changes:7777

## 5.11 Device Info Setup Menu

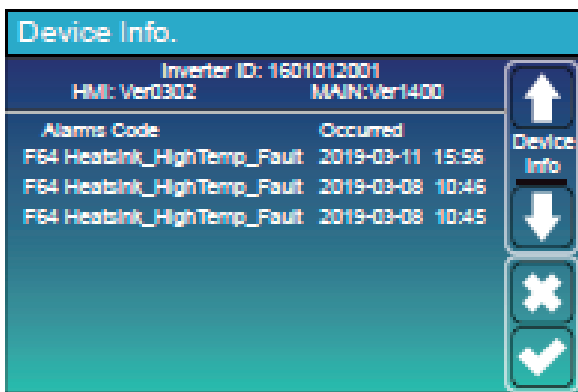

This page show Inverter ID, Inverter version and alarm codes.

HMI: LCD version  
 MAIN: MCU version

# 6. Mode

## Mode I:Basic

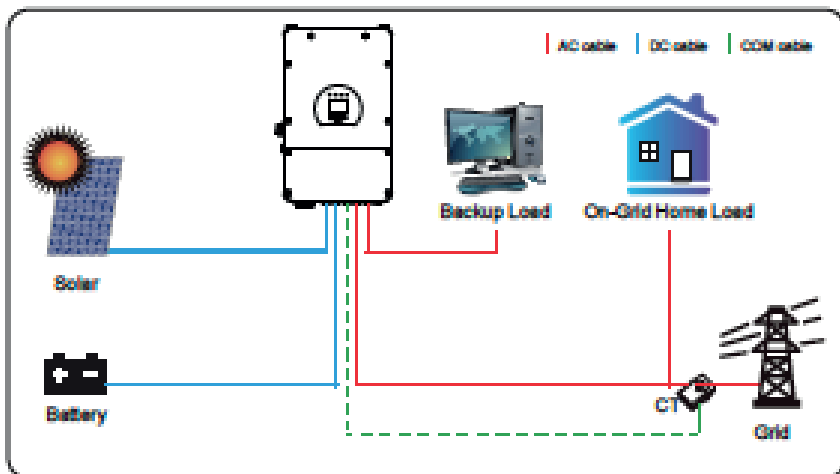



## Mode II: With Wind Turbine

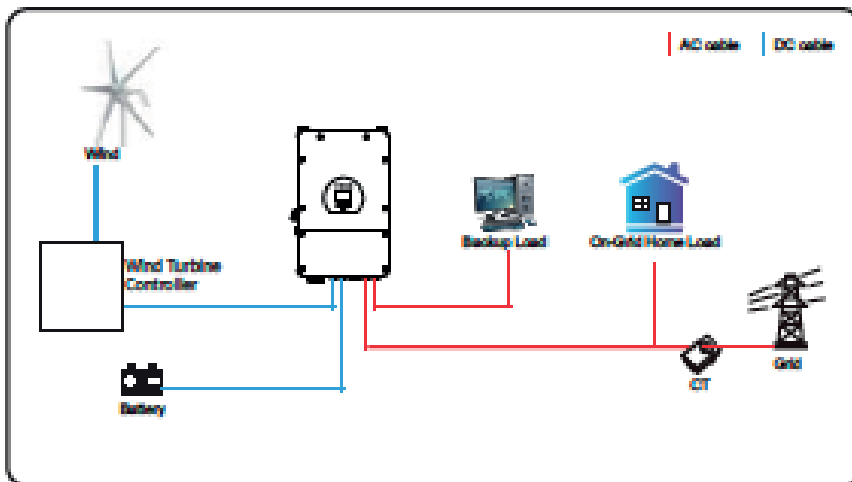

## Mode III: With Generator

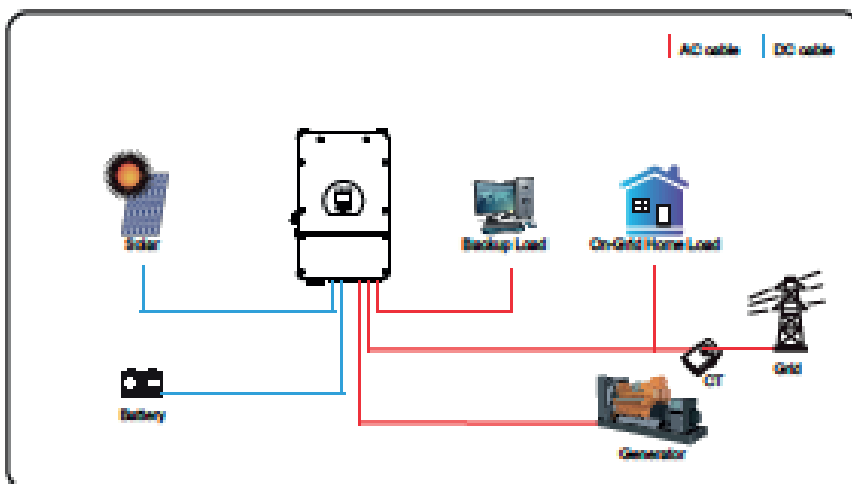

## Mode IV: With Smart-Load

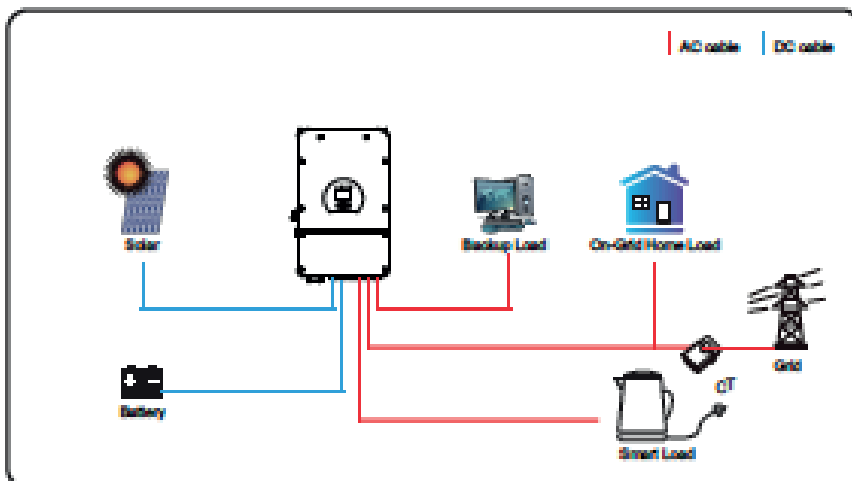

## Mode II: With Wind Turbine

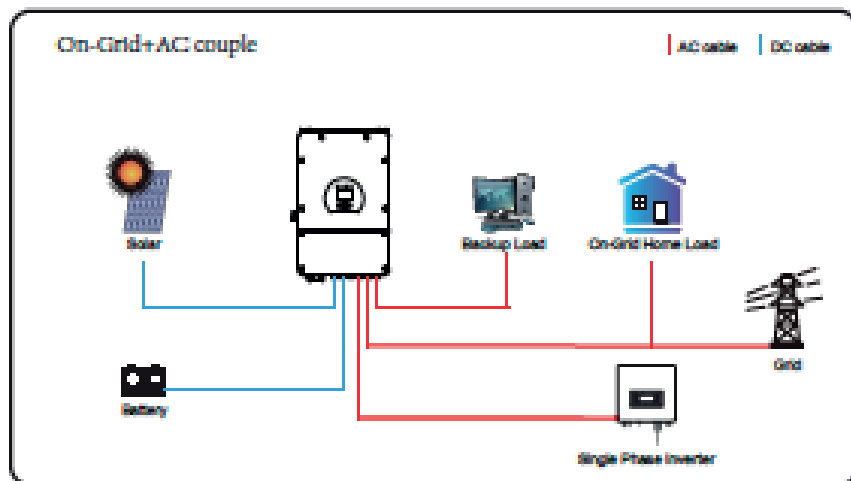

The 1st priority power of the system is always the PV power, then 2nd and 3rd priority power will be the battery bank or grid according to the settings. The last power backup will be the Generator if it is available.

## 7. Fault Information and Processing

The energy storage inverter is designed according to the grid-connected operation standard and meets the safety requirements and electromagnetic compatibility requirements. Before leaving the factory, the inverter undergoes several rigorous tests to ensure that the inverter can operate reliably.



If any of the fault messages listed in Table 6-1 appear on your inverter and the fault has not been removed after restarting, please contact your local dealer or service center. You need to have the following information ready.

1. Inverter serial number;
2. Distributor or service center of the inverter ;
3. On-grid power generation date;
4. The problem description (including the fault code and indicator status displayed on the LCD) is as detailed as possible.
5. Your contact information. In order to give you a clearer understanding of the inverter's fault information, we will list all possible fault codes and their descriptions when the inverter is not working properly.

In order to give you a clearer understanding of the inverter's fault information, we will list all possible fault codes and their descriptions when the inverter is not working properly.

**Chart 7-1 Fault information**

<b>Error Code</b>	<b>Description</b>	<b>Solutions</b>
F13	Working mode change	Inverter work mode changed 1. wait for a minute and check; 2. Seek help from us, if can't go back to normal state.
F18	AC over current fault of hardware	AC side over current fault 1. Please check whether the backup load power and common load power are within the range; 2. Restart and check whether it is in normal; 3. Seek help from us, if can not go back to normal state.
F20	DC over current fault of the hardware	DC side over current fault 1. Check PV module connect and battery connect; 2. Turn off the DC switch and AC switch and then wait one minute,then turn on the DC/AC switch again; 3. Seek help from us, if can not go back to normal state.
F23	AC leakage current is transient over current	Leakage current fault 1. Check the cable of PV module and inverter; 2. Restart inverter; 3. Seek help from us, if can not go back to normal state.
F24	DC insulation impedance failure	PV isolation resistance is too low 1. Check the connection of PV panels and inverter is firmly and correctly; 2. Check whether the PE cable of inverter is connected to ground; 3. Seek help from us, if can not go back to normal state.
F26	The DC busbar is unbalanced	1. Please wait for a while and check whether it is normal; 2. If still same, and turn off the DC switch and AC switch and wait for one minute and then turn on the DC/AC switch; 3. Seek help from us, if can not go back to normal state.
F35	No AC grid	No Utility 1. Please confirm grid is lost or not; 2. Check the grid connection is good or not; 3. Check the switch between inverter and grid is on or not; 4. Seek help from us, if can not go back to normal state.
F42	AC line low voltage	Grid voltage fault 1. Check the AC voltage is in the range of standard voltage in specification; 2. Check whether grid AC cables are firmly and correctly connected; 3. Seek help from us, if can not go back to normal state.
F47	AC over frequency	Grid frequency out of range 1. Check the frequency is in the range of specification or not; 2. Check whether AC cables are firmly and correctly connected; 3. Seek help from us, if can not go back to normal state.
F48	AC over frequency	Grid frequency out of range 1. Check the frequency is in the range of specification or not; 2. Check whether AC cables are firmly and correctly connected; 3. Seek help from us, if can not go back to normal state.

Error Code	Description	Solutions
F56	DC busbar voltage is too low	Battery voltage low 1. Check whether battery voltage is too low; 2. If the battery voltage is too low, using PV or grid to charge the battery; 3. Seek help from us, if can not go back to normal state.
F63	ARC fault	1. ARC fault detection is only for US market; 2. Check PV module cable connection and clear the fault
F64	Heat sink high temperature failure	Heat sink temperature is too high 1. Check whether the work environment temperature is too high; 2. Turn off the inverter for 10mins and restart; 3. Seek help from us, if can not go back to normal state.

Under the guidance of our company, customers return our products so that our company can provide service of maintenance or replacement of products of the same value. Customers need to pay the necessary freight and other related costs. Any replacement or repair of the product will cover the remaining warranty period of the product. If any part of the product or product is replaced by the company itself during the warranty period, all rights and interests of the replacement product or component belong to the company.

Factory warranty does not include damage due to the following reasons:

- Damage during transportation of equipment;
- Damage caused by incorrect installation or commissioning;
- Damage caused by failure to comply with operation instructions, installation instructions or maintenance instructions;
- Damage caused by attempts to modify, alter or repair products;
- Damage caused by incorrect use or operation;
- Damage caused by insufficient ventilation of equipment;
- Damage caused by failure to comply with applicable safety standards or regulations;
- Damage caused by natural disasters or force majeure (e.g. floods, lightning, overvoltage, storms, fires, etc.)

## 8. Limitation of Liability

In addition to the product warranty described above, the state and local laws and regulations provide financial compensation for the product's power connection (including violation of implied terms and warranties). The company hereby declares that the terms and conditions of the product and the policy cannot and can only legally exclude all liability within a limited scope.

## 9. Datasheet

Technical Data	5kW US	8kW US	5kW EU	8kW EU
<b>Battery Input Data</b>				
Battery Type	Lead-acid or lithium-ion			
Battery Voltage Range (V)	40V - 60V			
Max. Charging Current (A)	120A	135A	190A	190A
Max. Discharging Current (A)	120A	135A	190A	190A
Charging Curve	3 Stages/ equalization			
External Temperature Sensor	Optional			
Charging Strategy for Li-ion Battery	Self-adaption to BMS			
<b>PV String Input Data</b>				
Max. DC Input Power (W)	6500W	7800W	9880W	10400W
PV Input Voltage (V)	370V (100V ~ 500V)			
MPPT Range (V)	125V - 425V			
Start-up Voltage (V)	150V			
PV Input Current (A)	11A + 11A	18A + 9A	18A + 18A	18A + 18A
No. of MPPT Trackers	2			
No. of Strings per MPPT Tracker	1 + 1	2 + 1	2 + 2	2 + 2
<b>AC Output Data</b>				
Rated AC Output and UPS Power (W)	5000W	6000W	7600W	8000W
Max AC Output Power (W)	5500W	6600W	8360W	8800W
Peak Power (off-grid)	2 times of rated power, 10S			
AC Output Rated Current (A)	20.8A	25A	31.7A / 33A	33.4A / 35A
Max AC Current (A)	24A	28.8A	36.4A / 38A	38.3A / 40A
Max Continuous AC Passthrough (A)	35A	35A	50A	50A
Output Frequency and Voltage	50/60Hz; 120/240Vac(split phase), 208Vac(2/3 phase), 230Vac(single phase)			
Grid Type	Split phase, 2/3 phase, Single Phase			
Current Harmonic Distortion	THD<3%(Linear loading<1.5%)			

<b>Efficiency</b>	
Max. Charging Current (A)	97.60%
Battery Type	97.00%
Battery Voltage Range (V)	99.90%
<b>Protection</b>	
PV Arc Fault Detection	Integrated (Except European Type)
PV Input Lightning Protection	Integrated
Anti-islanding Protection	Integrated
PV String Input Reverse Polarity Protection	Integrated
Insulation Resistor Detection	Integrated
Residual Current Monitoring Unit	Integrated
Output Over Current Protection	Integrated
Output Shorted Protection	Integrated
Output Over Voltage Protection	Integrated
<b>Certifications and Standards</b>	
Grid Regulation	UL1741,IEEE1547,RULE21,VDE 0126,AS4777,NRS2017,G98,G
Safety Regulation	IEC62109-1, IEC62109-2
EMC	EN61000-6-1, EN61000-6-3, FCC 15 class B
<b>General Data</b>	
Operating Temperature Range (°C)	-25~60°C, >45°C Derating
Cooling	Fan
Noise (dB)	<30
Communication with BMS	RS485; CAN
Weight (Kg)	32Kg
Size	680 x 420 x 233mm
Protection Degree	IP65
Instillation Style	Wall-mounted
Warranty	5 Years

# SolarAdvice

Solar Advice (PTY) LTD  
Business Registration: 2016/333717/07  
VAT registration: 476 027 9861

021 012 5336  
010 312 6075  
[sales@solaradvice.co.za](mailto:sales@solaradvice.co.za)  
[www.solaradvice.co.za](http://www.solaradvice.co.za)